

36/1

T.O. 33A1-8-5-1
(Formerly AN 16-3OPRM10-1)

HANDBOOK OPERATION INSTRUCTIONS

TEST OSCILLATOR SET AN/PRM-10

(STAMFORD ELECTRONICS
AND
TAFLET RADIO & TV)

THIS PUBLICATION REPLACES T.O. 33A1-8-5-1, DATED 23 AUGUST 1968.

PUBLISHED UNDER AUTHORITY OF THE SECRETARY OF THE AIR FORCE

1 SEPTEMBER 1978

SECTION I GENERAL DESCRIPTION

1-1. GENERAL.

1-2. This is the Handbook of Operation Instructions for Test Oscillator Set AN/PRM-10, manufactured by Stamford Electronics Co., Stamford, Conn. and Taffet Radio and Television Co., Woodside, N. Y.

1-3. DESCRIPTION.

1-4. Test Oscillator Set AN/PRM-10 (figure 1-1) consists of the tuning head, power supply and seven plug-in type oscillator coil assemblies. These components are housed in a waterproof combination case.

1-5. The power supply is mounted in the combination case by means of captive screws. This allows easy removal of the power supply when it is necessary to replace electron tubes. One side of the power supply is pierced with holes to act as dummy sockets that hold the plug-in oscillator coil assemblies. The power cable,

and the cord to the tuning head are both permanently attached, mechanically and electrically, to the power supply.

1-6. The tuning head contains a socket-type terminal board where any one of the oscillator coil assemblies can be plugged in. The tuning head fits inside the combination case, on top of the power supply. The cord connecting it to the power supply is permanently attached mechanically and electrically. The tuning head is used as a probe. It contains a sensitive meter which accurately indicates resonant frequencies. Frequencies are read on the frequency indicator dial which is seen through a transparent plastic window in the tuning head case.

1-7. Table 1-1 shows the components of this test oscillator set. No other components are required.

Table 1-1. Equipment Supplied

Quantity	Component
1	Tuning Head
1	Power Supply and Combination Case
1	Oscillator Coil Assy, 2 to 5 mc
1	Oscillator Coil Assy, 5 to 10 mc
1	Oscillator Coil Assy, 10 to 22 mc
1	Oscillator Coil Assy, 22 to 45 mc
1	Oscillator Coil Assy, 45 to 100 mc
1	Oscillator Coil Assy, 100 to 250 mc
1	Oscillator Coil Assy, 250 to 400 mc

1-8. PURPOSE OF EQUIPMENT. This test oscillator set is a portable test equipment designed primarily to provide means for rapidly determining resonant frequencies of tuned circuits, or the frequency of radio signals. It may also be used as a variable frequency oscillator. This provides a choice of modulated or unmodulated signals for testing, aligning and calibrating radio receivers and similar equipment.

1-9. FUNCTION. This test oscillator set may be regarded as a miniature radio receiver or transmitter. It is placed close to the equipment or circuit to be tested or calibrated. The word "coupling" is used to denote this action. The particular plug-in oscillator coil assembly plugged into tuning head acts as the receiving or transmitting antenna. Results are observed on the meter in the tuning head or heard in headphones. The "TUNING" dial scale provides definite frequency readings.

1-10. CAPABILITIES. This test oscillator set is a rugged, portable instrument primarily intended for use in organizational and field maintenance. It may be used either as a frequency meter or as a signal generator.

1-11. LIMITATIONS. When operated as a signal generator, the test oscillator set is not intended to be a frequency standard except within tolerances of plus or minus 1½ percent. Also, the test oscillator set is used entirely as a probe. It has no output cables. Coupling is always inductive through the oscillator coil assembly projecting from the top of the tuning head.

1-12. FREQUENCY RANGE. This equipment covers frequencies from 2 to 400 megacycles in seven ranges. These ranges are provided by plug-in type oscillator coil assemblies whose frequencies are stated in Table 1-1. Overlap between ranges is ten percent or more.

1-13. TYPE OF SIGNAL. Either continuous wave, or modulated continuous wave signals are produced by this test oscillator set. The instrument includes a 1000-cycle oscillator circuit. Approximately 30 percent amplitude modulation is produced by this circuit. External amplitude modulation from 50 to 10,000 cycles may be supplied from an external oscillator. Approximately one volt across 150,000 ohms is required from an external oscillator to produce 30 percent modulation.

1-14. POWER REQUIREMENTS. This test oscillator set requires 105-125 volts at 50-1000 cycles, single phase, and draws 20 watts.

CAUTION

Do not connect to direct current or 25-cycle supply.

SECTION II

OPERATING PROCEDURES

2-1. GENERAL.

2-2. The test oscillator set is a portable instrument. Ordinarily, the tuning head is held in one hand and tuned with the other. Frequency is read on the "TUNING" dial scale and points of resonance are clearly apparent in the form of sharp changes in the meter reading. The tuning head is used as a probe. It is brought close to the equipment under test so that a signal may either be inserted or picked up through the oscillator coil assembly plugged into the tuning head.

Note

Press oscillator coil assemblies all the way into the sockets. Coils must always seat fully.

2-3. DESCRIPTION OF CONTROLS.

a. "POWER" switch (1, figure 2-1). This switch energizes the unit when the power cord is plugged into a 105-125-volt, 50-1000-cycle power source.

b. "OSC.-DIODE" switch (2). In "OSC." position the unit functions as a radio frequency oscillator. In "DIODE" position the unit functions as a diode detector or absorption wavemeter.

c. "MOD.-CW" switch (3). This switch determines the characteristics of the output signal. In "MOD." position the carrier is modulated approximately 30 percent at 1000 cycles. In "CW" position the carrier is unmodulated. This switch is useful only if "OSC.-DIODE" switch is in "OSC." position.

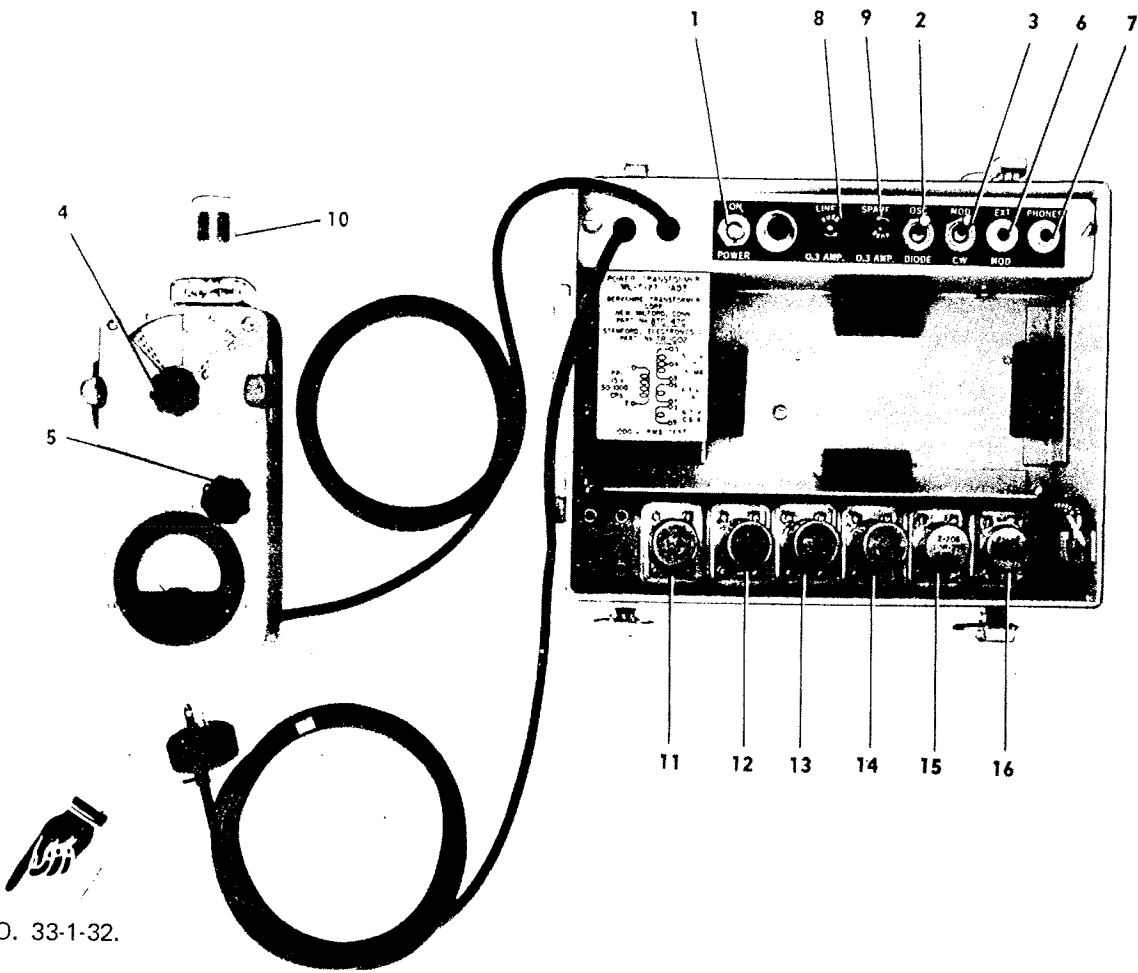

SEE T.O. 33-1-32.

- | | |
|------------------------|-------------------------------------|
| 1. "POWER" SWITCH | 9. "SPARE FUSE" |
| 2. "OSC.-DIODE" SWITCH | 10. 2-5 MC OSCILLATOR COIL ASSY |
| 3. "MOD.-CW" SWITCH | 11. 5-10 MC OSCILLATOR COIL ASSY |
| 4. "TUNING" KNOB | 12. 10-22 MC OSCILLATOR COIL ASSY |
| 5. "METER ADJUST" KNOB | 13. 22-45 MC OSCILLATOR COIL ASSY |
| 6. "EXT. MOD." JACK | 14. 45-100 MC OSCILLATOR COIL ASSY |
| 7. "PHONES" JACK | 15. 100-250 MC OSCILLATOR COIL ASSY |
| 8. "LINE FUSE" | 16. 250-400 MC OSCILLATOR COIL ASSY |

Figure 2-1. Operation Controls Test Oscillator Set AN/PRM-10

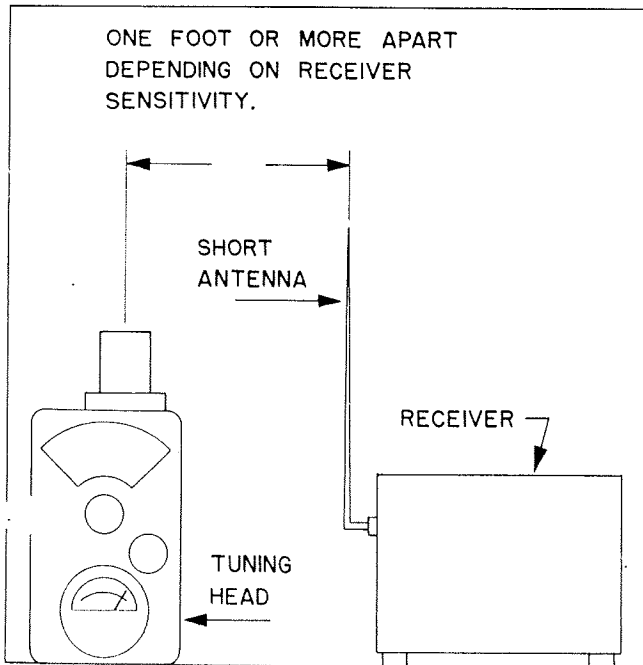

Figure 2-4. Coupling With Temporary Antenna

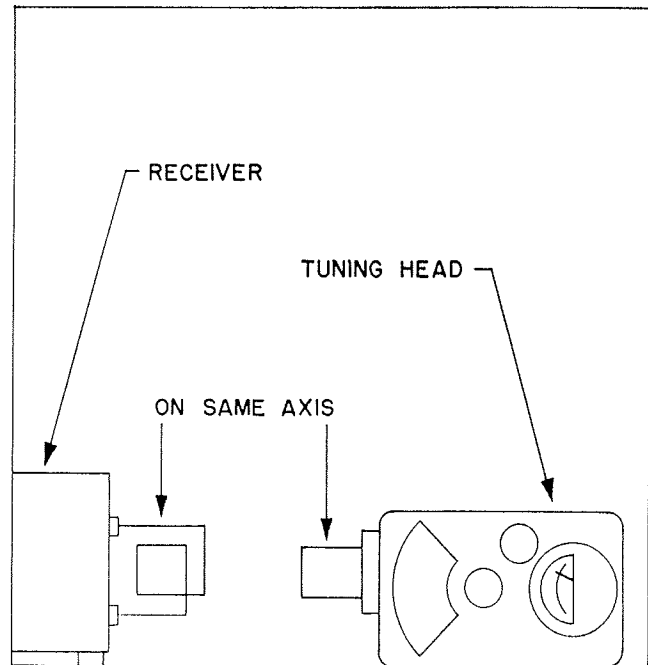

Figure 2-5. Coupling With Loop Antenna

2-12. ABSORPTION TYPE WAVEMETER OPERATION.

- a. Energize equipment to be tested.
- b. Connect to power source and turn "POWER" switch (1, figure 2-1) to "ON" position. Allow 30 seconds for electron tubes to warm up.
- c. Put "OSC.-DIODE" switch (2) in "DIODE" position.
- d. Turn "METER ADJUST" knob (5) fully clockwise.
- e. Select proper frequency. Plug in oscillator coil assembly.
- f. Arrange coupling either as shown in figure 2-2 or figure 2-3.

2-13. Meter reading will be low while tuning. At the incoming signal's frequency, the tuning meter rises to a peak reading. Loose coupling with low peak readings is most accurate.

CAUTION

Use a coupling distance of several feet from transmitter circuits to prevent harm to the instrument.

2-14. When it is impossible to tell what frequency to expect in the circuit under test, it is necessary to take and record a number of readings over a wide frequency range. The frequency separating meter peaks or sound in the headphones is the fundamental frequency.

2-15. R-F SIGNAL GENERATOR OPERATION.

2-16. The test oscillator set may be used as a signal generator for the alignment and adjustment of r-f and i-f circuits operating between 2 and 400 mc. Turn "POWER" switch (1, figure 2-1) to "ON" position. Turn "MOD.-CW" switch (3) to the desired position and "OSC.-DIODE" switch (2) to "OSC." position.

2-17. Coupling is secured by means of a short antenna added to the equipment under test. (See figure 2-4.) When a radio receiver has a loop antenna, align the axis of the tuning head with the axis of the loop. (See figure 2-5.) In general it is desirable to keep the test oscillator set some distance from the equipment to avoid overloading circuits.

2-18. The test oscillator set provides signals for the adjustment of resonant antennas. The antenna may be fed at the center or end. Use the oscillator coil assembly of proper frequency and turn the "TUNING" knob (4, figure 2-1) to the exact frequency desired. Arrange switches as directed in paragraph 2-16. Use a second test oscillator set or a field strength meter to read signal strength as the antenna is adjusted.

SPECIAL NOTICE

To stop equipment in an emergency, turn off the "POWER" switch. Pull the plug of the power cord out of the connector at the power source.

SECTION III

OPERATING CHECKS AND ADJUSTMENTS

3-1. PRELIMINARY CHECK.

3-2. Before using the test oscillator set, test it for meter deflection.

- a. Connect 105-125-volt, 50-1000-cycle supply.
- b. Turn "POWER" switch (1, figure 2-1) to "ON" position.
- c. Allow 30 seconds for tubes to warm up.
- d. Insert the 2-5 mc oscillator coil assembly.
- e. Set "METER ADJUST" knob (5) fully clockwise for maximum sensitivity.
- f. Set "OSC.-DIODE" switch (2) to "OSC." position.

3-3. Tune through the full range of the dial. A nor-

mal instrument should provide full scale deflection of the meter pointer.

3-4. CHECK DURING OPERATION.

3-5. If meter reading drops below zero during grid-dip meter operation, as stated in paragraphs 2-5 through 2-8 the tuning head is held too close to the unenergized tuned circuit and too much power is absorbed. Move the instrument back to get looser coupling.

3-6. When a tuned circuit is energized during absorption meter type operation as described in paragraphs 2-12 and 2-13, the readings will be zero or very low until the instrument is tuned to resonance. Then the meter pointer should rise to a peak reading.

SECTION IV

EMERGENCY OPERATION AND REPAIR

4-1. EMERGENCY OPERATION.

4-2. Emergency operation of the test oscillator set is not recommended. It is a test instrument which is used in keeping other equipment in proper condition. Therefore, it should not be used if it shows any damage, or fails to indicate full scale deflection of the meter pointer when tuned as directed in paragraphs 3-1 through 3-5.

4-3. REPLACEMENT OF TUNING HEAD ELECTRON TUBE.

4-4. If there is less than full scale deflection of the meter pointer during the preliminary check described in paragraphs 3-1 through 3-3, replace the electron tube V-201. (See figure 4-1.)

- a. Remove four screws holding top case assembly.
- b. Remove the "TUNING" knob and felt washer by loosening the setscrews with the Allen wrench provided in the power supply. Then lift off the top case assembly.
- c. Using long nose pliers slide off the coil clip from the middle terminal of electron tube V-201.
- d. Twist electron tube V-201 counterclockwise until the pins slip out of the four lock lugs that form the socket.

CAUTION

Do not pull out on the electron tube—it must be twisted out of the lugs.

- e. Twist a new electron tube V-201 into place.
- f. Replace coil clip.

g. Carefully put the top case assembly back into place. Be careful to line up the grounding contact springs so they interlock smoothly without crumpling or bending.

h. Check operation as instructed in paragraphs 3-2 and 3-3.

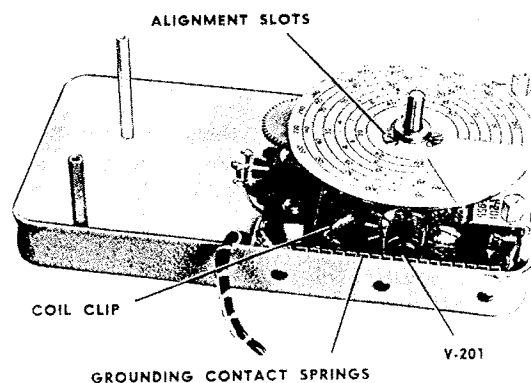

Figure 4-1. Location of Electron Tube in Tuning Head

Paragraph 4-5 to 4-7

4-5. REPLACEMENT OF POWER SUPPLY ELECTRON TUBES. Remove the tuning head and oscillator coil assemblies. Loosen the four captive screws that hold the power supply in the combination case. Lift out the power supply chassis, turn it over and take the following steps. (See figure 4-2.)

a. Remove electron tube shields by pressing down, twisting counter-clockwise and then withdrawing.

b. Remove electron tubes by pulling out.

c. Replace electron tubes by turning until the pins enter the individual sockets and then pressing down.

d. Replace electron tube shields.

e. Replace power supply in combination case and tighten the captive screws.

4-6. REPLACEMENT OF FUSE. When necessary, the fuse (8, figure 2-1) is removed from the power supply by turning the knob under "LINE FUSE" and withdrawing. Insert the spare fuse and discard the old one. If the new fuse burns out, disconnect power from the instrument and investigate cause of the short circuit.

4-7. REPLACEMENT OF PILOT LIGHT. The pilot light in the power supply can be removed and replaced from the front. Unscrew the red jewel cover. Then push down on the lamp and turn counter-clockwise to withdraw.

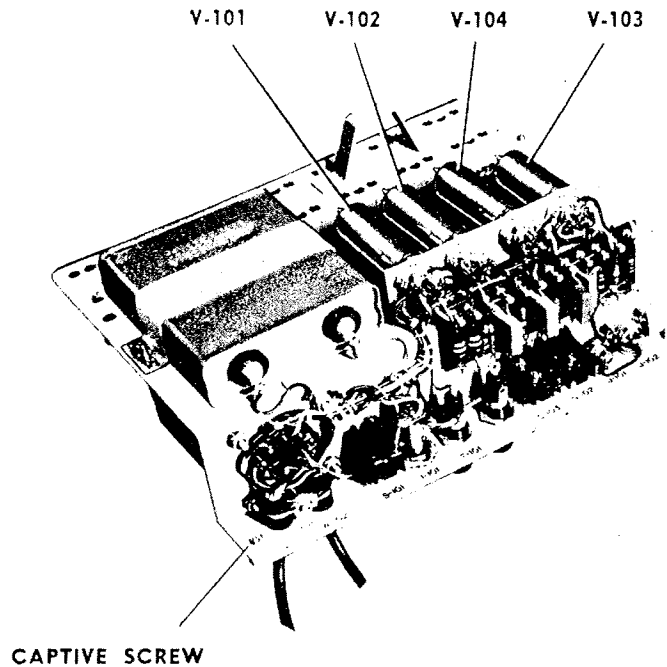

Figure 4-2. Location of Electron Tubes in Power Supply

SECTION VI

FIELD AND FASRON MAINTENANCE

6-1. MINIMUM PERFORMANCE STANDARDS.

6-2. Check proper performance of the test oscillator set in all seven frequency ranges.

a. Plug the power cable in on 115-volt, 50-1000-cycle supply.

b. Put switch (S-101, figure 7-1) in "ON" position. Put switch (S-102) in "MOD." position. Put switch (S-103) in "OSC." position. This arranges the test oscillator set as a signal generator.

c. Use a second test oscillator set with headphones inserted and switches in "ON" and "DIODE" positions, and with "METER ADJUST" knob fully clockwise to receive the generated signals.

d. Insert oscillator coils (Z-201 through Z-207, figure 7-1) into each tuning head, a pair of the same frequency range at a time. Couple the tuning heads end to end so that the oscillator coils are about one foot apart.

e. Tune the second test oscillator set through the frequency shown by test oscillator set which is being serviced. A beat note or click will be heard in the headphones, and a flicker of the pointer of meter (M-201, figure 7-1) will occur when the incoming signal is received. Tune slowly so as not to pass the resonant point without noticing it.

f. If a signal is received with any of the oscillator coils it proves that the tuning head and power supply are operating properly, but coils that do not oscillate should be replaced.

g. Before replacing oscillator coils make certain that their contact pins are clean and make genuine electrical contact when plugged into the tuning head. Always plug coils in fully or frequency accuracy may be upset.

6-3. SYSTEMS TROUBLE ANALYSIS.

6-4. REMOVAL. Remove the "TUNING" knob and the four screws in the corners of the top case assembly. Lift it off of the tuning head. Loosen the four captive screws in the corners of the power supply chassis and then lift it out of the combination case.

6-5. VOLTAGE AND CONTINUITY CHECKS.



Internal voltages of test voltmeters are sufficient to damage meter M-201. Put a 100,000-ohm resistor in series with one test lead. This assumes 6 volts as the test meter voltage and provides a possible 60 percent deflection of meter M-201.

6-6. When the test oscillator does not operate after new electron tubes have been put in and the meter checked, make the voltage and continuity checks outlined in Table 6-1. Test points mentioned in Table 6-1 appear on figure 7-1. Figure 7-2 is the practical wiring diagram which guides the finding of test point locations in the equipment.

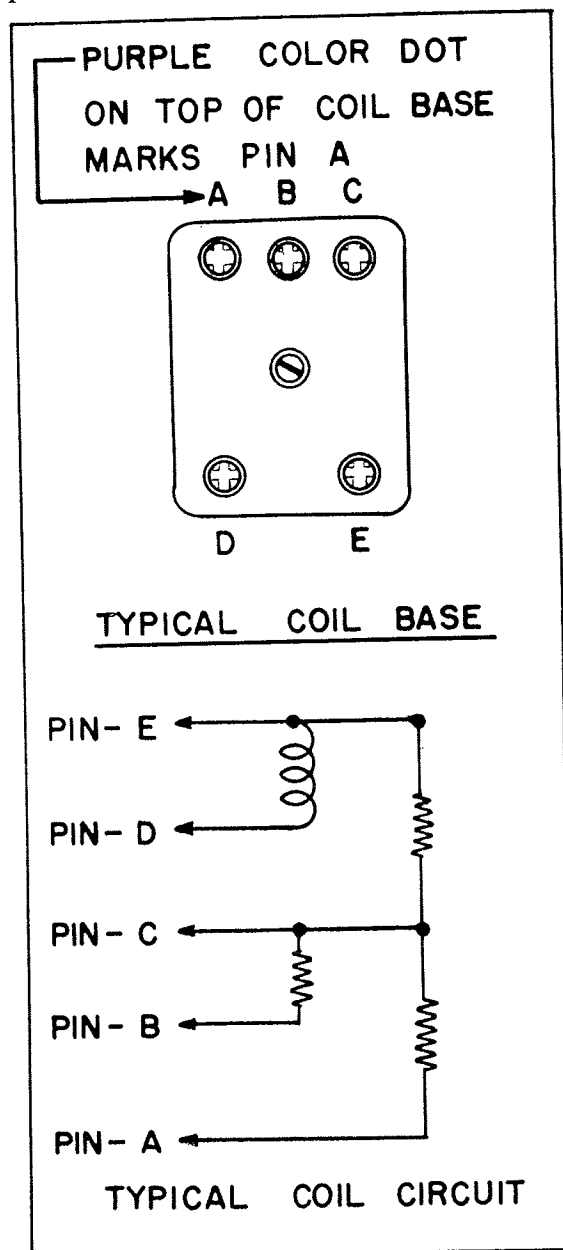

Figure 6-1. Identification of Oscillator Coil Contact Pins

Paragraph 6-7 to 6-11

6-7. Check electron tube socket terminal voltages in accordance with figure 7-3. Check electron tube socket resistance values in accordance with figure 7-4. With both voltage and resistance, variation of plus or minus 10 percent is permissible. But, any reading that is sharply different requires that the associated circuit be checked.

6-8. OSCILLATOR COIL CHECK. Refer to the oscillator coils (Z-201 through Z-207, figure 7-1) when any oscillator coil is suspected of not working. Figure 6-1 identifies the contact pins in the bases of the coils. Check for the continuity and resistance values shown by figure 7-1.

6-9. ALIGNMENT. After repairing a test oscillator set, check its accuracy by comparing its frequency dial indications with another test oscillator set. Follow the instructions given in paragraph 6-2. Tune slowly and observe frequency dial readings accurately. When fre-

quency dial readings do not agree, adjust the repaired unit's frequency dial position. Loosen the three screws in the slotted holes in the frequency dial and shift the dial on the shaft. When either capacitor (C-201ABC, Figure 5-1) or variable resistor (R-208) are replaced, turn both their shafts fully counter-clockwise. Then turn the shaft of variable resistor (R-208) clockwise, the distance of one gear tooth. Then tighten gear set screws.

6-10. MAINTENANCE AND INSPECTION. Each time the test oscillator set is used check the sensitivity as directed in paragraph 5-2. The minimum meter reading of 40 percent is required.

6-11. OVERHAUL SCHEDULE. Replace electron tube V-201 after the test oscillator set has operated for 300 hours. No further routine overhaul is scheduled because there is practically no mechanical wear and electrical loadings are low.

Table 6-1. Systems Trouble Analysis Chart (Sheet 1 of 3)





Step	Test Points	Test Equipment Control Position	AN/PRM-10 Control Position	Normal Indication	Possible Cause of Abnormal Indication
1	 Pin 5 of electron tube V-102 to ground.	20,000-ohm per volt voltmeter. Use 250-volt d-c scale.	Power connected. Turn "POWER" switch "ON." Plug in 2-5 mc oscillator coil. Turn "METER ADJUST" knob until meter reads 100. "OSC.-DIODE" switch in "OSC." "MOD.-CW" switch in "CW" "TUNING" knob at 3.5 mc.	150 volts d-c	Transformer T-101, Electron tubes V-101, V-102, capacitor C-101, resistors R-101, R-102.
2	 Pin 7 of electron tube V-103 to ground.	Same as Step 1.	Same as step 1.	60 volts d-c	Resistor R-103, R-104, capacitor C-102, electron tube V-103 and associated parts.
3	 Pin 5 of electron tube V-104 to ground.	Same as step 1, but 1000-volt d-c scale.	Same as step 1.	310 volts	Electron tube V-104 and associated parts.
4	 Pin 2 of electron tube V-104 to ground.	Same as step 1, use 250-volt d-c scale.	Same as step 1.	155 volts d-c	Electron tube V-104, capacitors C-103, C-104, C-105, resistors R-108, R-109.
5	 Pin 2 of electron tube V-201 to ground.	Same as step 4.	Same as step 1.	105 volts d-c	Resistor R-201, electron tube V-201, Cord W-102.

Table 6-1. System Trouble Analysis Chart—(Cont.) (Sheet 2 of 3)

Step	Test Points	Test Equipment Control Position	AN/PRM-10 Control Position	Normal Indication	Possible Cause of Abnormal Indication
6	⑤ Pin 2 of electron tube V-201 to ground.	High resistance scale. Put a 100,000-ohm resistor in series with one voltmeter lead to protect meter M-201 in tuning head.	Disconnect power. Remove oscillator coil. Vary "METER ADJUST" knob.	Continuity.	Resistors R-201, R-203, R-205.
7	Ⓐ Green lead on switch S-103 to Ⓐ ₁ negative terminal of meter M-201	Same as step 6.	Same as step 6.	Continuity.	Meter M-201 green wire in cord W-102.
8	Ⓐ Negative terminal of meter M-201 to Ⓐ ₂ terminal of resistor R-206.	Same as step 6.	Same as step 6.	Continuity.	Resistor R-206.
9	Ⓐ ₁ Negative terminal of meter M-201 to Ⓐ ₃ terminal of resistor R-207.	Same as step 6.	Same as step 6.	Continuity.	Resistor R-207.
10	Ⓐ ₃ Terminal of resistor R-207 to Ⓐ ₄ terminal of terminal board TB-202.	Same as step 6 but remove 100,000-ohm resistor.	Turn "TUNING" knob through full rotation.	0 to 10,000 ohms as knob is turned.	Resistor R-208, winding or contact arm.
11	Ⓐ ₄ Terminal of terminal board TB-202 to Ⓐ ₅ terminal of terminal board TB-202.	Same as step 10.	No adjustment required.	10,000 ohms.	Resistor R-208 and associated wiring.
12	Ⓑ ₁ Terminal of terminal board TB-202 to Ⓑ ₁ terminal of Resistor R-202.	Same as step 10.	Same as step 10.	No continuity.	Capacitor C-201ABC.
13	Ⓑ ₁ Terminal of resistor R-202 to ground.	Same as step 10.	Same as step 10.	470 ohms.	Resistor R-202.

Table 6-1. System Trouble Analysis Chart—(Cont.) (Sheet 3 of 3)

Step	Test Points	Test Equipment Control Position	AN/PRM-10 Control Position	Normal Indication	Possible Cause of Abnormal Indication
14	(B ₂) Terminal of terminal board TB-202 to ground.	Same as step 10.	Same as step 10.	100,000 ohms.	Resistor R-204.
15	(5) Pin 2 of electron tube V-201 to ground.	Same as step 10.	Same as step 10.	530,000 ohms, varies slightly with movement of "TUNING" knob.	Resistors R-201, R-203 and R-205.
16	(C) Pin 5 of electron tube V-201 to ground.	Same as step 10.	Same as step 10.	Continuity to 50 ohms.	R-f choke assembly L-201.
	(D) Pin 1 of electron tube V-103 to ground.	Same as step 10.	Same as step 10 but change switch S-102 to "MOD." position.	150,000 ohms.	Resistor R-106.
18	(E) Pin 2 of electron tube V-103 to ground.	Same as step 10.	No adjustment required.	4,700 ohms.	Resistor R-107.

SECTION VII

DIAGRAMS

7-1 GENERAL.

7-2. This section contains four figures, the schematic wiring diagram (figure 7-1), and the practical wiring diagram (figure 7-2), the electron tube terminal voltage diagram (figure 7-3), and the electron tube terminal resistance diagram (figure 7-4).

7-3. Both the schematic wiring diagram (figure 7-1), and the practical wiring diagram (figure 7-2), contain the same reference symbol numbers. Power supply parts are covered within the "100" block of reference symbol numbers. Tuning head parts are covered by the "200" block of reference symbol numbers. Identical reference

symbol numbers are also stamped in black ink either on, or next to the actual electrical parts.

7-4. The schematic wiring diagram (figure 7-1), shows the entire circuit of the test oscillator set and shows the location of all test point identification symbols. The practical wiring diagram (figure 7-2), gives the location of each part and shows the color coding of each wire.

7-5. Figures 7-3 and 7-4 illustrate the location of the contact pins in the electron tube sockets and list the voltages and resistances associated with these pins. Take readings tabulated in these two figures with the electron tubes in the sockets.

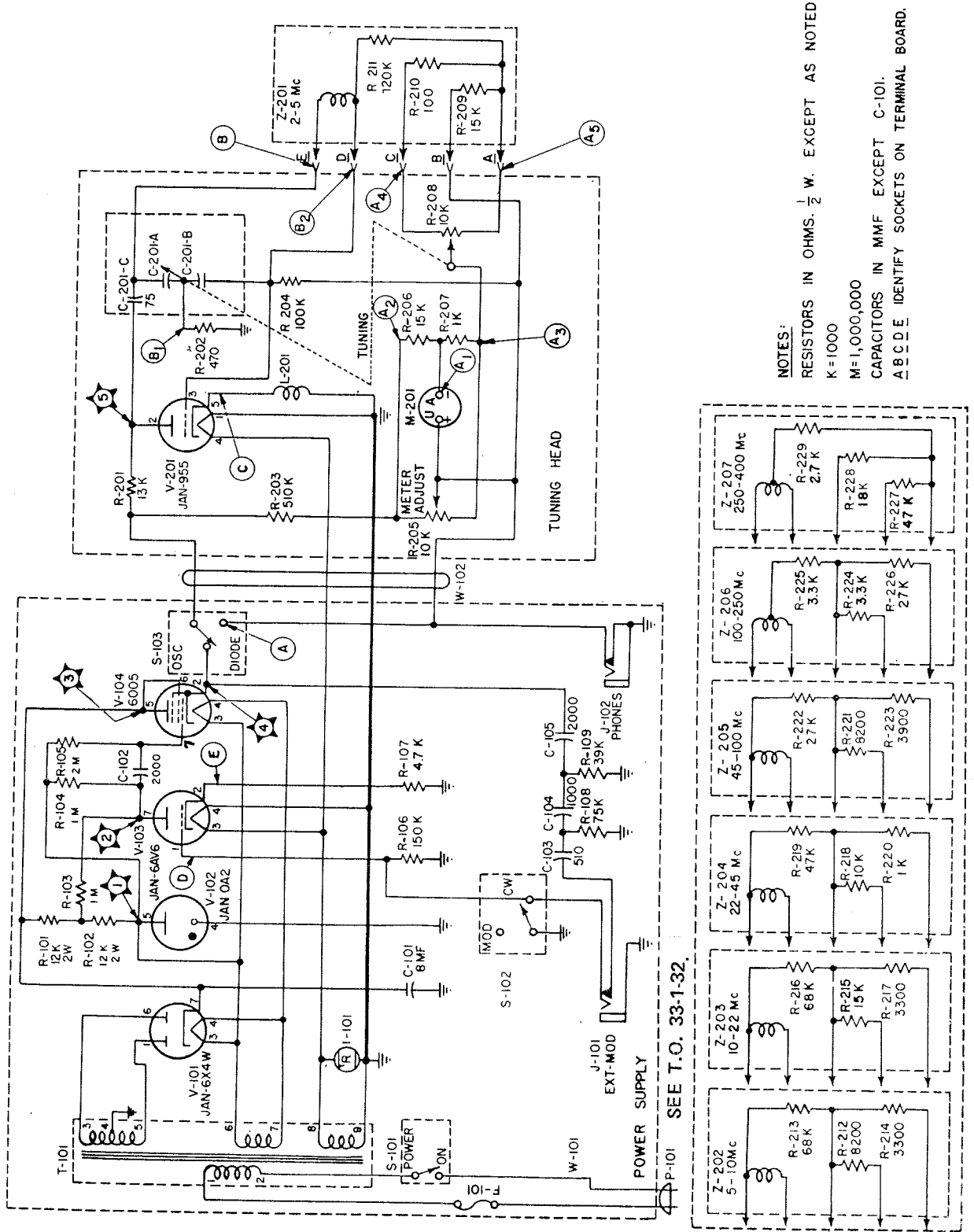

Figure 7-1. Test Oscillator Set AN/PRM-10, Schematic Wiring Diagram with Test Points Identified

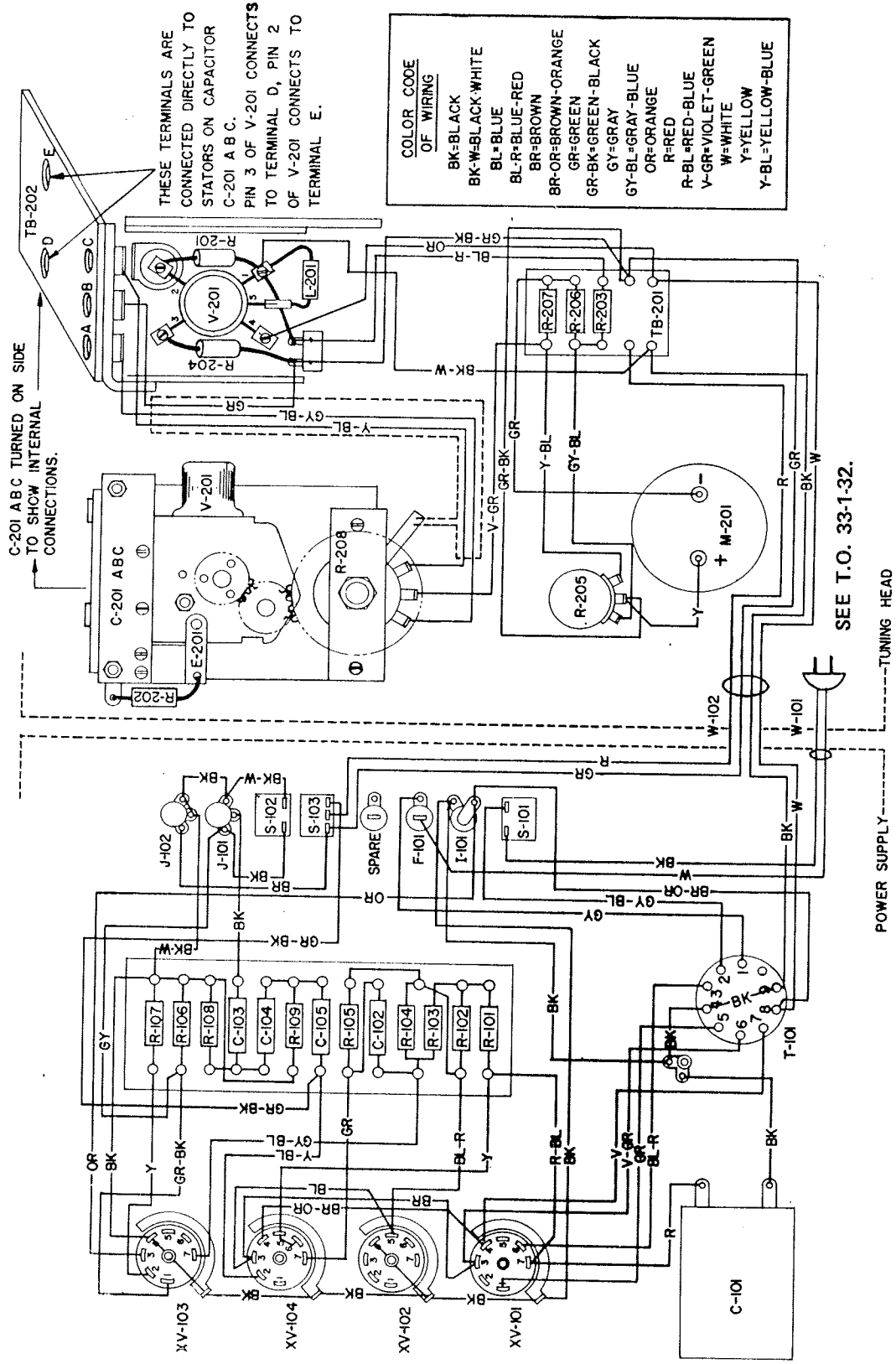

Figure 7-2. Test Oscillator Set AN/PRM-10, Practical Wiring Diagram

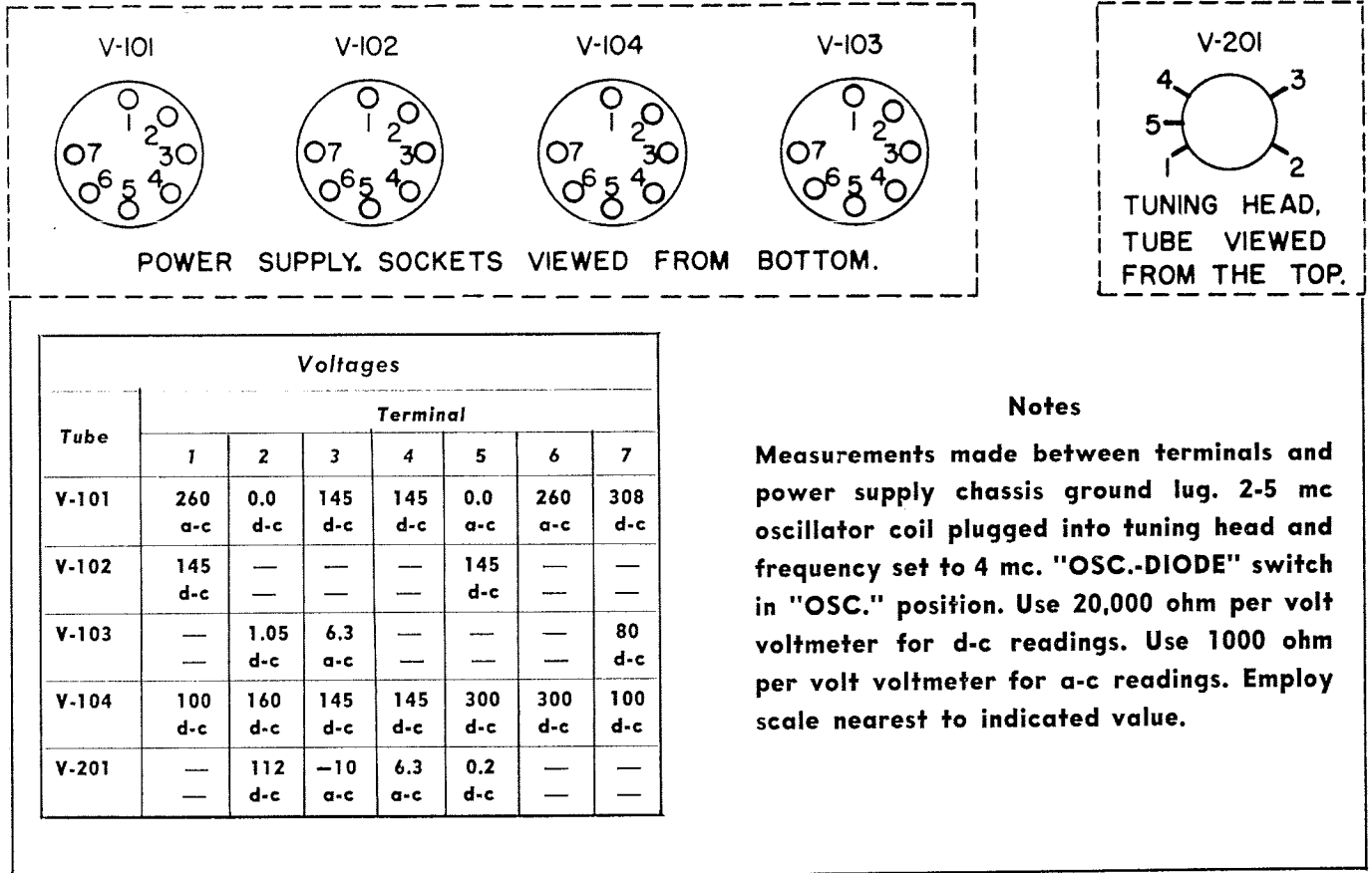
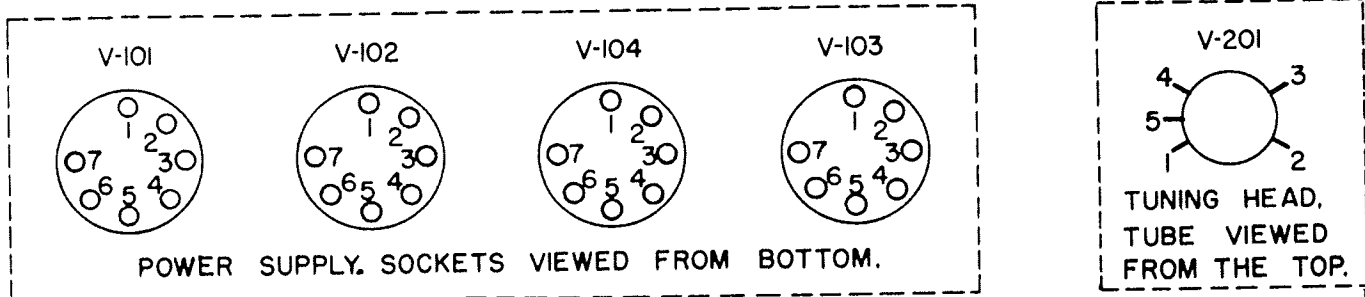

Figure 7-3. Electron Tube Socket Terminal Voltage Diagram



Resistance in Ohms

Tube	Terminal						
	1	2	3	4	5	6	7
V-101	900	0.0	0.0	0.0		900	0
V-102	Infinity	0.0	Infinity	0.0	24K*	Infinity	0
V-103	150K	4.7K	0.3	0.0	Infinity	Infinity	Infinity
V-104	Infinity	500K	Infinity	Infinity	Infinity	Infinity	Infinity
V-201	0.7	500K	100K	0.3	42		

Notes

Measurements made between socket terminals and power supply chassis ground lug. 2.5 mc oscillator coil plugged into tuning head and frequency set to 4 mc. "OSC.-DIODE" switch in "OSC." position. "MOD.-CW" switch in "MOD." position. Use meter scale giving maximum readable deflection. K = 1000, M = 1,000,000

* Resistance increases as Capacitor C-101 charges.

Figure 7-4. Electron Tube Socket Terminal Resistance Diagram